

POWERWALL-WALL MOUNTED



INSTALL EASILY



LONG CYCLE LIFE



HIGH ENERGY RATIO



PARALLELEABLE



NO POLLUTION



IP65 RATED



Wall-WALL MOUNTED

The W48100B-IP65 is designed to be highly waterproof and widely used indoor and outdoor. Single battery pack 5KWh, it can be connected to expand power according to actual power demand by parallel. It is made by EVE grade A LFP cells, which have good performance in high and low temperature resistance with long life span and high safety. It can be easily combined with solar energy to supply power to home users day and night.

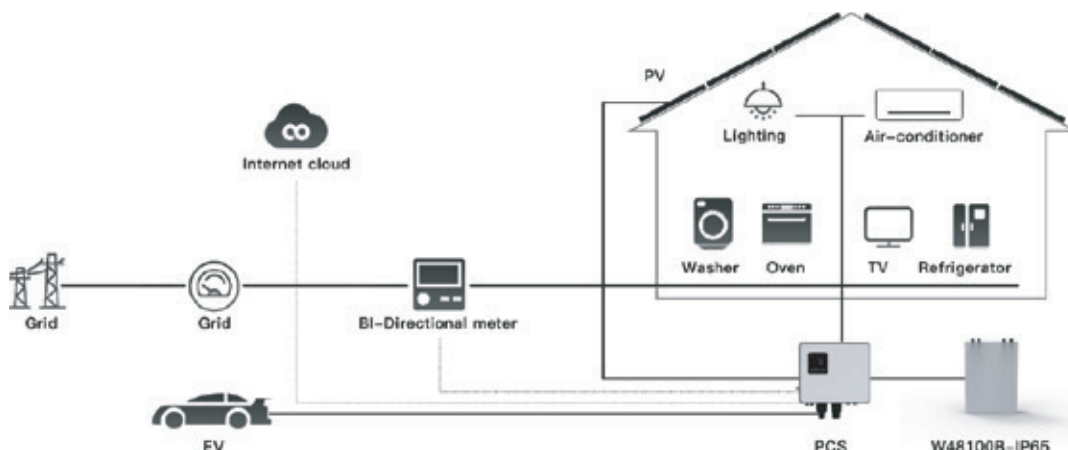

SPECIFICATIONS

Model	W48100B-IP65
Rated power [Wh]	5120
Rated voltage [V]	51.2
Cell capacity [Ah]	100
Length [mm]	673±3
Width [mm]	473±3
Height [mm]	172±3
Weight [Kg]	46
Inner resistance [m]	≤60
Max. charge voltage [V]	58.4
Discharge cut-off voltage [V]	46
Standard charging current [A]	20
Continuous discharge current [A]	50
Max. Cont. discharge current [A]	100
Standard charging temperature [°C]	0~55
Standard discharge temperature [°C]	-20~55
Standard storage temperature [°C]	-20~60
Cooling method	Natural cooling
Safety standard	UL1973, UL9540, UN38.3, MSDS, CE(IEC62368), ROHS
Storage humidity	5%~95%
Warranty [year]	5+5